

Libec
Craftsmanship from Japan

2021/22



Libec
www.libec-global.com

Beyond Quality Support

CONTENTS

3	Our Technology	47	Tripods
5	TH-G3	50	Pedestal Systems
6	TH-M	55	Tracking Rails, Jibs & Remote Head
7	Heads & Tripods	56	Tracking Rails
8	650EX	57	SWIFT JIB
9	TH-X	61	REMOTE HEAD
11	TH-Z	63	Remote Controls, Tripod Cases & Accessories
14	Libec Sliders	64	Remote Controls
15	NX	66	Tripod Cases
21	LX	68	Camera Bags
25	RS	69	Accessories
33	RS PLUS	73	Specifications
41	QD		



Our Technology

Importance of Counterbalance

When looking for a suitable tripod head for your camera, one of the most important aspects to consider is counterbalancing capability. The counterbalancing function provides a counterforce to keep the balance between the tripod head and the camera that is mounted on it. If the right counterbalance is maintained, the camera remains stationary at any angle of tilt. You do not need to worry about holding the camera by hand and yet are able to maintain precise control of the camera.

Counterbalancing Capability

RS/RS PLUS/QD is equipped with an excellent counterbalancing system that provides a perfect counterforce that corresponds to the weight and angle of the camera. A special innerspring mechanism is used for this system. When the strength of a spring is insufficient, the head cannot bear the weight of the camera. If a spring is too strong, the camera will tilt upward. RS/RS PLUS/QD "variable counterbalance system" enables users to adjust the strength of the innerspring within a certain range using the counterbalance knob located on the outside of the head. Different cameras can be used and a perfect counterbalance can be set for each individual camera.

Counterbalance Chart to Help you Choose the Perfect Tripod Head

The definitive way to find the most accurate counterbalance between camera/accessories and a tripod head is to actually mount the camera on the head. However, you can use this counterbalance chart to get a rough idea of the correct counterbalance. The vertical axis of the chart depicts the height of the gravitational center and the horizontal axis is load weight (total weight of the camera and accessories). Based on the combination of these two elements, you can find a suitable tripod head for your camera. The area between the two curved lines represents the range of counterbalance that you can set with the counterbalance adjustment knob. When a standard lens, microphone and battery are used, the normal height of the gravitational center is approximately 200mm/7.9"(box lens), 125mm/4.9"(shoulder type camera) and 75mm/3"(hand-held camera). The height of the gravitational center will not shift much even when a different lens or a different battery is used on the back of the camera. Please be aware that attaching a light or a monitor on top of the camera will shift the center of gravity.



Fine-tunable counterbalance knob

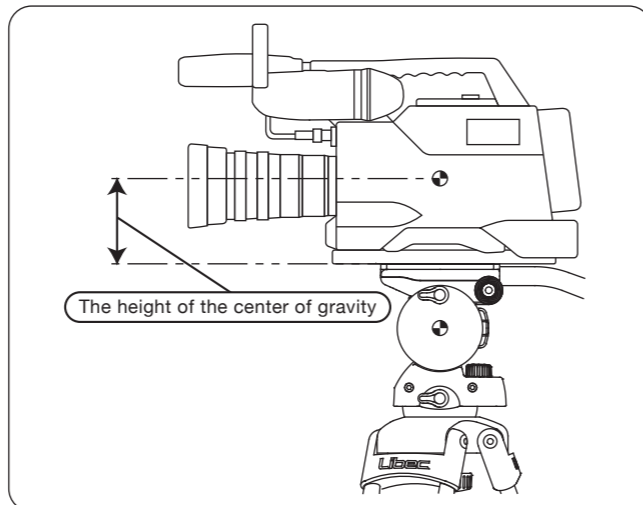

The height of the center of gravity is the distance from the center of the camera to the top of the head (or the camera plate). The shorter this distance, the higher the weight point becomes.

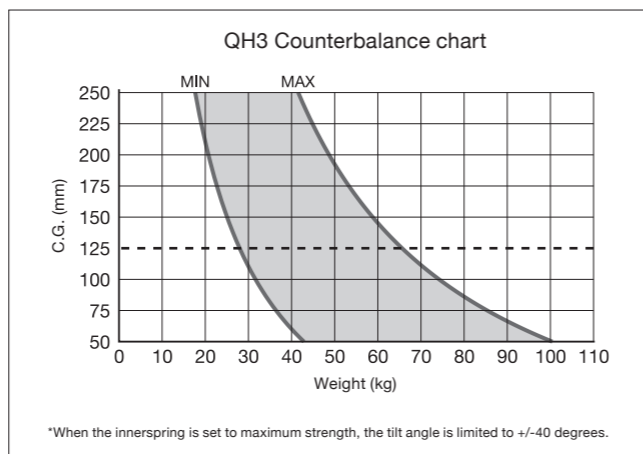

Smooth Balancing, the spring tension gets stronger as the counterbalance adjustment knob is turned clockwise, increasing tension on the knob. This difficulty is simplified by the head's **smooth balancing system** which stabilizes the turning force efficiently. The knob can be turned with constant force and offers easy and speedy adjustments.

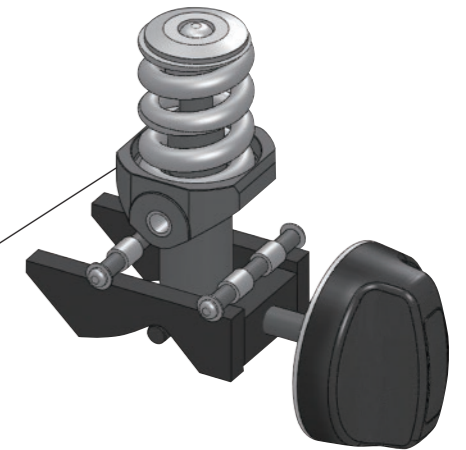

Drag System

The sealed drag unit contributes to the smooth start and stop of pan and tilt movement, and produces precise camerawork just as intended. In addition, specific silicon grease is applied to ensure ordinary pan and tilt movement at a wide temperature range from -40°C / -40°F up to +60°C / +140°F (QD from -20°C / -4°F up to +60°C / +140°F). The variable seven-step drag switch system covers remarkably wide drag range, by which an optimum drag is selectable according to every shooting condition and circumstances.



SNAP ON/OFF PLATE

TH-X / TH-Z/ NX / RS PLUS / QD is equipped with a camera plate that is attachable and detachable with just one touch, promoting speedy and easy setup.

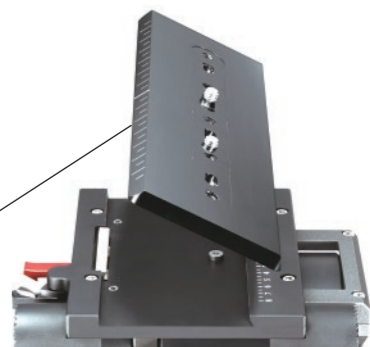

TH-G3

MULTI-ACTION GIMBAL

TH-G3 Multi-Action Gimbal can support a wide range of cameras weighing from 0.5kg to 3.6kg. The TH-G3 has multiple action modes. By connecting to Libec's smart phone App, motion time-lapse, remote controls, and detailed adjustments can be achieved. Designed with a long battery life of 18 hours, users can enjoy many hours of recording comfortably.



High Payload Range

With a high payload range from 0.5kg to 3.6kg, the TH-G3 supports a wide range of cameras from mirrorless cameras to full-size DSLR with multiple types of lenses.



Four Follow Modes

To greatly assist on photo and video shoots, the TH-G3 has four follow modes including "Pan Follow Mode", "Pan & Tilt Follow Mode", "Lock Mode", and "Roll Follow Mode". Simply switch between modes by pressing the button.



TH-G3 Multi-Action Gimbal **New**

Payload	Min.500g Max.3600g / Min.1.1lb Max.7.9lb
Operation time	Min.12h Max.18h Static operation under proper balance
Charging time	6h
Input vol.	Min.11.2v Standard14.8V Max.16.8V
Operation current	Min.150mA Max.7600mA
Operation temperature	Min.-10°C Standard +25°C Max.+45°C Min.+14°F Standard +77°F Max.+113°F
Tilt angle range	360° Unlimited rotation
Roll angle range	360° Unlimited rotation
Pan angle range	360° Unlimited rotation
Following deviation in static state	Min.±0.01° Max. ±0.03°
Following deviation in motion state	Min.±0.05° Max. ±0.1°
Product dimension	192mm x 79mm x 460mm / 7.6" x 3.1" x 18.1"
Weight	1470g/ 3.2lbs Excluding batteries
Accessory ports	Mechanical: 1/4" and 3/8" Mounting/Screw holes Electrical: 8V/2A Power Accessory Port, Camera Control Port
User interface	Bluetooth 4.0

Recommended Accessories



TH-M

HANDS-FREE MONOPOD

By stepping on the lock/release foot pedals, conveniently located symmetrically in three sections on the Free-stand Base, you are able to quickly lock/release the monopod during photo and video shoots.

Perfect Lock Feature

When users lock the bottom part of the monopod by stepping on the foot pedal, the ball joint will be locked as well. The pan movement of the head on the monopod is smoother than ever, allowing the users to control the camera's manual focus while panning at the same time when shooting.

Upgraded Head Attachment

The former HFMP monopod can only support equipment with a 3/8" screw hole. However, the new TH-M's head attachment is equipped with both a 1/4" screw and a 3/8" screw.

Improved Rigidity

Advanced head attachment made with new aluminum material to maximize the monopod's rigidity.

Easy to Maintain

The Free-stand Base has been redesigned allowing users to easily remove dirt when necessary.

* Bowl clamp included (TH-M KIT only)

* The monopod's maximum payload does not guarantee a monopod's free-stand position, it only guarantees the monopod's maximum payload when using as a monopod.



TH-M **New**

TH-M KIT **New**

Payload	8kg / 17.6lb (Including head)	4kg / 8.8lb (C.G. 55mm)
Tilt angle	—	+90° / -80°
Dual pan function design	—	Pan function on head
Temperature range	—	-20°C to +60°C / -4°F to +140°F
Weight	1.8kg / 4.0lb	2.7kg / 5.9lb
Height	74.0 to 176.0cm / 29.1 to 69.3"	87.5 to 189.5cm / 34.4 to 74.6"
Section	2STAGE	2STAGE
Leg lock type	Lock/ Release Levers	Lock/ Release Levers
Head attachment	1/4" screw, 3/8" screw	1/4" screw, 3/8" screw
Camera plate	—	Sliding plate Compatible with Manfrotto and Sachtler heads
Construction material	Aluminum	Aluminum
Pipe diameters (upper/mid/low)	34.0mm / 29.5mm / 25.0mm	34.0mm / 29.5mm / 25.0mm
Monopod case	Included	Included

650EX



650EX **New**

Payload	3kg / 6.6lb
Counterbalance	FIX
Drag mode	FIX
Tilt angle	+90° / -70°
Temperature range	-20°C to +60°C / -4°F to +140°F
Bubble level	Non illuminated
Camera plate	Sliding plate Compatible with Manfrotto and Sachtler heads
Sliding range	+/-30mm / 1.2"
Plate attachment	1/4" screw with video pin
Spare screw	None
Weight	3.3kg / 7.3lb
Height	70.5 to 150.5cm / 27.8 to 59.3"
Head attachment	65mm bowl
Section	2STAGE

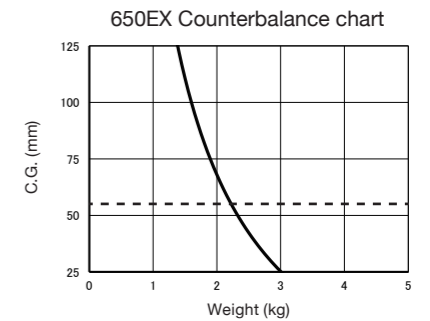

Sliding Plate Range for Camera Balance

The 650EX is equipped with a sliding plate range that allows users to balance their camera even quicker, a key improvement from the previous model's fixed quick shoe.

One-touch Flip Locks

Designed with efficient one-touch flip locks, users can quickly adjust and set their tripod's height between shots and when necessary.

Transport Lock

During transportation, the 650EX tripod legs can be locked into place thanks to the equipped transport lock.

Rubber Foot Pads with Metal Spikes

Designed with quality rubber footpads for most indoor video shoots. When shooting outdoors, the tripod can be firmly planted on the ground by twisting the footpads and exposing the conveniently hidden metal spikes.



TH-X

Smart Tripod Companion

With improved operability, stability, and rigidity, the TH-X is by far the best tripod system that Libec has designed in this range.



Head

SNAP ON/OFF PLATE

Equipped with a one touch attach and release mechanism. Also, the sliding plate is compatible with Manfrotto and Sachtler heads, for speedy and easy setups in the field.



Tripod

Compact & Robust

Compact diameter of only 105mm/4.1" when folded. Newly designed legs and leg locks, the rigidity is greatly enhanced compared to other tripods, while maintaining an amazing lightness of 1.1kg/2.4lb.

DUAL HEAD

Dual-head specification available for both 65mm bowl and flat base tripods. Mountable on sliders, skater dollies, and other equipment.



SNAP ON/OFF PLATE

DUAL HEAD

TH-X H

Payload	4kg / 8.8lb
Counterbalance	FIX
Drag mode	FIX
Tilt angle	+90° / -80°
Temperature range	-20°C to +60°C / -4°F to +140°F
Bubble level	Non Illuminated
Camera plate	Sliding plate Compatible with Manfrotto and Sachtler heads
Sliding range	+/-30mm / 1.2"
Head base	65mm ball / Flat base
Plate attachment	1/4" screw with video pin
Spare screw	None
Weight	1.1kg / 2.4lb

TH-X H Counterbalance chart

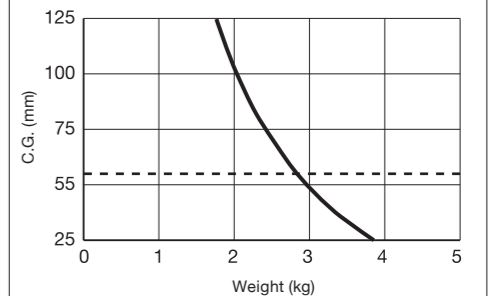

* Bowl clamp included



TH-X

Weight	3.1kg / 6.9lb
Height	75.5 to 159cm / 29.7 to 62.6"
Head attachment	65mm bowl
Section	2STAGE

Recommended Accessories

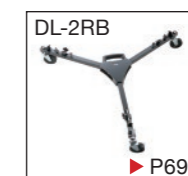



TH-Z

SNAP ON OFF PLATE DUAL HEAD

TH-Z H

Payload	5kg / 11lb
Counterbalance	FIX
Drag mode	FIX
Tilt angle	+90° / -80°
Temperature range	-20°C to +60°C / -4°F to +140°F
Bubble level	Illuminated
Camera plate	Sliding plate Compatible with Manfrotto and Sachtler heads
Sliding range	+/-30mm / 1.2"
Head base	75mm ball / Flat base
Plate attachment	1/4" screw with video pin
Spare screw	None
Weight	1.1kg / 2.4lb

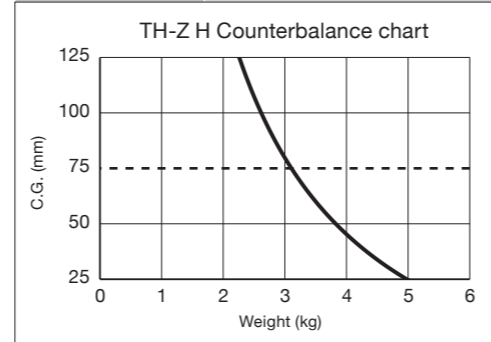

* Bowl clamp included

TH-Z T

Pipe material	Aluminum
Weight	2.4kg / 5.3lb
Height	58.5 to 149cm / 23 to 58.5"
Head attachment	75mm bowl
Section	2STAGE



Head

SNAP ON OFF PLATE

Equipped with a one touch attach and release mechanism. Also, the sliding plate is compatible with Manfrotto and Sachtler heads, for speedy and easy setups in the field.

DUAL HEAD

Dual-head specification available for both 75mm bowl and flat base tripods. Mountable on sliders, skater dollies, and other equipment.

Lightweight

Total weight of only 1.1kg/2.4lb including the pan handle.



LED bubble level

Tripod

Rigidity

In spite of its lightweight of only 2.4kg/5.3lb, the TH-Z tripod has a high rigidity. The extendable brace provides good stability when mounting sliders.

TH-Z

SNAP **ON OFF** PLATE
DUAL **HEAD**



TH-Z

Weight	3.5kg / 7.7lb
Height	71.5 to 161.5cm / 28 to 63.5"
Head attachment	75mm bowl
Section	2STAGE



TH-Z S4 KIT

Weight	4.9kg / 10.8lb
Head attachment	75mm bowl
Section	2STAGE



TH-Z S8 KIT

Weight	5.3kg / 11.7lb
Head attachment	75mm bowl
Section	2STAGE

Recommended Accessories

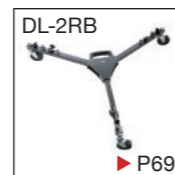

Libec Sliders

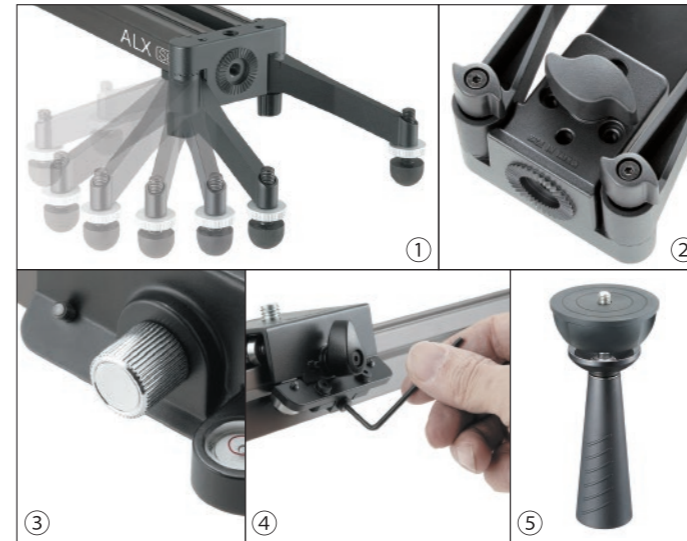

Usability

- ① Legs open and close to 180 degrees that allows to store the slider into the carrying case without removing the legs.
- ② The rail can be easily detached and replaced by using the leg lock knob.
- ③ The spring-equipped friction knob enables precise weight adjustment for a smooth sliding movement.
- ④ Using the supplied hexagon wrench, pushing force of the ball bearing against the rail can be adjusted.
- ⑤ Tripod mount adapter and bowl clamp are included for mounting the slider on 75mm ball diameter tripods.



1. Slider body
2. Tripod mount adapter
3. Maintenance brush
4. Hexagon wrench (2.5mm / 0.1")
5. Bowl clamp
6. Padded carrying case

	ALX S4	ALX S8	ALX S12
Weight	1.4kg / 3.1lb *	1.8kg / 4lb *	2.5kg / 5.5lb *
Payload	15kg / 33lb **	15kg / 33lb **	15kg / 33lb **
Head attachment	3/8" screw	3/8" screw	3/8" screw
Screw holes on the rail's back side	1/4" and 3/8" screw holes	1/4" and 3/8" screw holes	1/4" and 3/8" screw holes
Rail length	400mm / 15.5"	800mm / 31.5"	1,200mm / 47"
Sliding range	308mm / 12"	708mm / 28"	1,108mm / 43.5"

* Weight exclude tripod mount adapter and bowl clamp.
** Payload when not attached to tripod.



The World's Lightest Video Tripod

NX
Japan Crafted



Head



SNAP ON/OFF PLATE

Equipped with a one touch attach and release mechanism. Also, the sliding plate is compatible with Manfrotto and Sachtler heads, for speedy and easy setups in the field.

DUAL HEAD

Dual - head specification available for both 75mm bowl and flat base tripods. Mountable on sliders, skater dollies, and other equipment.

LED bubble level

User Friendly Accessory Attachments

On the side of the fluid head, there are 1/4 and 3/8 inch screw holes to attach an accessory arm with a monitor or a light. Since the holes are located on the base, the payload capacity, center of gravity and front-rear balance are not affected.

Tripod

Newly Designed Carbon Legs, Foot Pads and Spreader

With a new lightweight structure design, the width of the carbon leg's upper pipe leg is widened to enhance torsional rigidity and provide high payload performance. Developed exclusively for the NX series, the FP-1B foot pads and SP-1B floor spreader are available. The newly designed foot pads and floor spreader are even lighter than the existing model FP-2B and SP-2B.



High Performance Lightweight Model for Mirrorless and Small Cameras

DUAL HEAD

Dual - head specification available for both 75mm bowl and flat base tripods. Mountable on sliders, skater dollies, and other equipment.



NH10 **New**

Counterbalance range	0 to 2.5kg / 0 to 5.5lb (C.G. 55mm)
Payload	4kg / 8.8lb
Counterbalance	Multistep Counterbalance
Counterbalance mode	Free plus 5STEP
Drag mode	Free plus 3STEP
Drag system	Multilayered Metal Structure
Tilt angle	+90° / -70°
Temperature range	-40°C to +60°C / -40°F to +140°F
Bubble level	Illuminated
Camera plate	Sliding plate Compatible with Manfrotto and Sachtler heads
Sliding range	+/-30mm / 1.2"
Long sliding plate	Optional
Head base	75mm ball / Flat base
Plate attachment	1/4" screw with video pin
Accessory attachments	1/4" and 3/8" screw holes
Spare screw	1/4" and 3/8" screws
Weight	1.8kg / 4.0lb

SNAP ON OFF PLATE

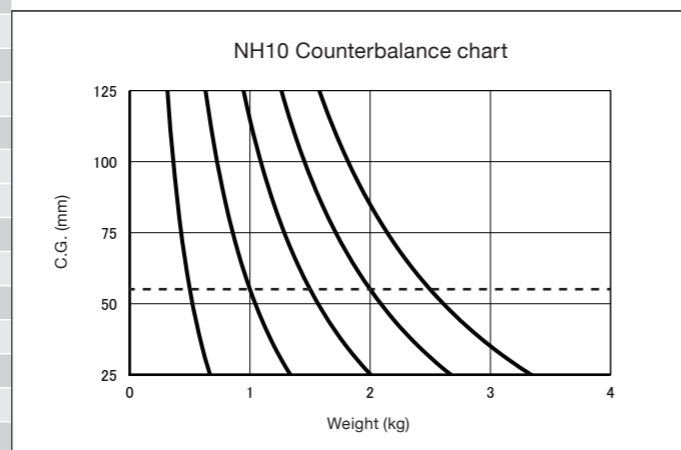

GOOD DESIGN AWARD 2020

NX-100C Carbon pipe **New**

NH10 / RT20C / SP-1B / RC-20 System with floor spreader

Weight	4.1kg / 9lb
Height	53 to 168cm / 20.8 to 66.1"
Head attachment	75mm bowl
Section	2STAGE



GOOD DESIGN AWARD 2020

NX-100MC Carbon pipe **New**

NH10 / RT20C / BR-2B / FP-1B / RC-20 System with mid-level spreader

Weight	3.8kg / 8.3lb
Height	80 to 167cm / 31.4 to 65.7"
Head attachment	75mm bowl
Section	2STAGE



Recommended Accessories

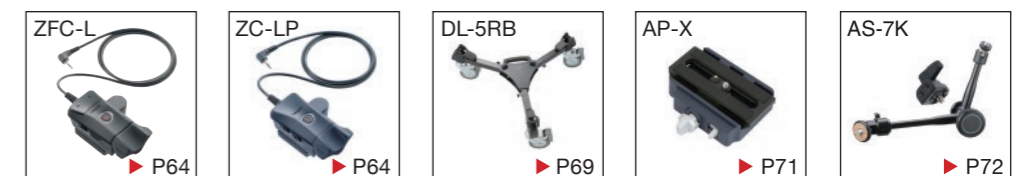

High Performance Lightweight Model for Professional Cameras Including Handheld Cameras

DUAL HEAD

Dual - head specification available for both 75mm bowl and flat base tripods. Mountable on sliders, skater dollies, and other equipment.



NH30 **New**

Counterbalance range	0 to 10kg / 0 to 22lb (C.G. 55mm)
Payload	10kg / 22lb
Counterbalance	Multistep Counterbalance
Counterbalance mode	Free plus 5STEP
Drag mode	Free plus 3STEP
Drag system	Multilayered Metal Structure
Tilt angle	+90° / -70°
Temperature range	-40°C to +60°C / -40°F to +140°F
Bubble level	Illuminated
Camera plate	Sliding plate Compatible with Manfrotto and Sachtler heads
Sliding range	+/-30mm / 1.2"
Long sliding plate	Included
Head base	75mm ball / Flat base
Plate attachment	1/4" screw with video pin
Accessory attachments	1/4" and 3/8" screw holes
Spare screw	1/4" and 3/8" screws
Weight	1.8kg / 4.0lb

SNAP ON OFF PLATE

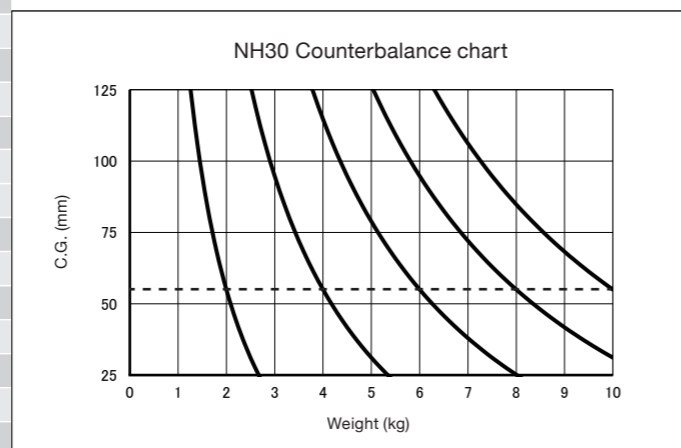

GOOD DESIGN
AWARD 2020



NX-300C Carbon pipe **New**

NH30 / RT20C / SP-1B / RC-20
System with floor spreader

Weight	4.1kg / 9lb
Height	53 to 168cm / 20.8 to 66.1"
Head attachment	75mm bowl
Section	2STAGE

NX-300MC Carbon pipe **New**

NH30 / RT20C / BR-2B / FP-1B / RC-20
System with mid-level spreader

Weight	3.8kg / 8.3lb
Height	80 to 167cm / 31.4 to 65.7"
Head attachment	75mm bowl
Section	2STAGE



GOOD DESIGN
AWARD 2020



Recommended Accessories

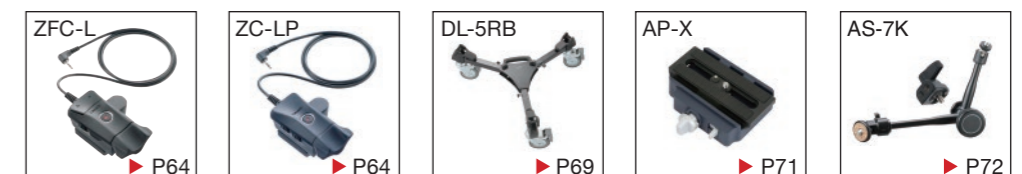

LX



Outstanding payload and rigidity with extremely smooth drag performance at the best value in the range. Remarkably high-performance features with incomparable cost effectiveness.

LX



Heads & Tripods

5

10

Cost Effective Model for Large Hand-held Cameras and Large Camcorders



LX5 New

LX5 Head / RT30B / SP-2B / TC-70
System with floor spreader

Weight	5.5kg / 12.1lb
Height	56 to 166cm / 22 to 65.5"
Head attachment	75mm bowl
Section	2STAGE

Payload	5kg / 11lb
Counterbalance	FIX
Drag mode	FIX
Tilt angle	+90° / -80°
Temperature range	-20°C to +60°C / -4°F to +140°F
Bubble level	Non illuminated
Camera plate	Sliding plate
Sliding range	+/-40mm / 1.6"
Head base	75mm ball
Plate attachment	1/4" screw with video pin
Spare screw	None

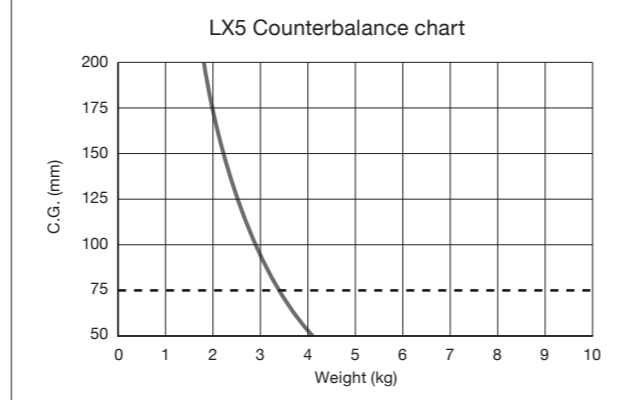

LX5 M New

LX5 Head / RT30B / BR-2B / FP-2B / TC-70
System with mid-level spreader

Weight	5.2kg / 11.4lb
Height	81 to 165.5cm / 32 to 65"
Head attachment	75mm bowl
Section	2STAGE

Payload	8kg / 17.5lb
Counterbalance	FIX
Drag mode	FIX
Tilt angle	+90° / -80°
Temperature range	-20°C to +60°C / -4°F to +140°F
Bubble level	Non illuminated
Camera plate	Sliding plate
Sliding range	+/-40mm / 1.6"
Head base	75mm ball
Plate attachment	1/4" screw with video pin
Spare screw	3/8" screw

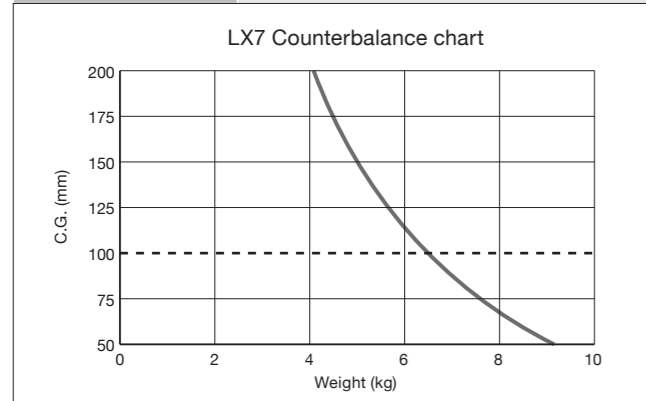

LX7

LX7 Head / RT30B / SP-2B / TC-70
System with floor spreader

Weight	5.5kg / 12.1lb
Height	56 to 166cm / 22 to 65.5"
Head attachment	75mm bowl
Section	2STAGE



LX7 M

LX7 Head / RT30B / BR-2B / FP-2B / TC-70
System with mid-level spreader

Weight	5.2kg / 11.4lb
Height	81 to 165.5cm / 32 to 65"
Head attachment	75mm bowl
Section	2STAGE



LX10

LX10 Head / RT50B / SP-2B / RC-50
System with floor spreader

Weight	7.6kg / 16.7lb
Height	63 to 173.5cm / 25 to 68.5"
Head attachment	100mm bowl
Section	2STAGE

Payload	16kg / 35lb
Counterbalance	FIX
Drag mode	2STEP
Tilt angle	+85° / -65°
Temperature range	-20°C to +60°C / -4°F to +140°F
Bubble level	Non illuminated
Camera plate	Sliding plate
Sliding range	+/-50mm / 2"
Head base	100mm ball
Plate attachment	3/8" screw x 2
Spare screw	3/8" screw

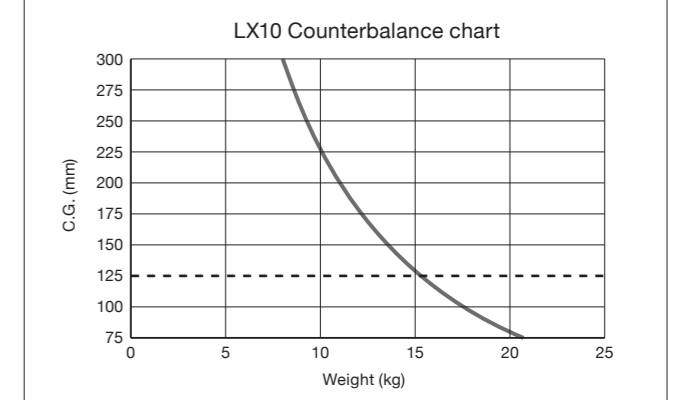

LX10 M

LX10 Head / RT50B / BR-6B / FP-2B / RC-50
System with mid-level spreader

Weight	7.4kg / 16.3lb
Height	83 to 171.5cm / 32.5 to 67.5"
Head attachment	100mm bowl
Section	2STAGE



LX10 Studio

LX10 Head (Dual pan handle) / RT50B / DL-3RB
System with dolly

Weight	10.9kg / 24lb
Height	91.5 to 187cm / 36 to 73.5"
Head attachment	100mm bowl
Section	2STAGE

Recommended Accessories

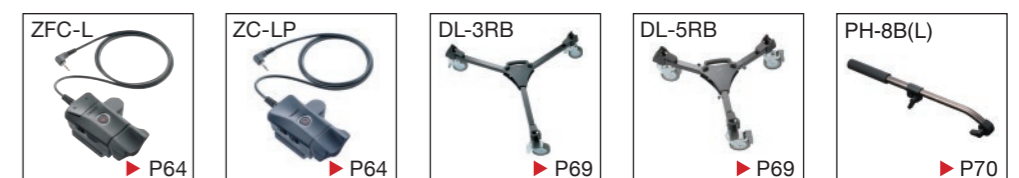

RS



The RS models feature their sophisticated high-functionality, backed by Libec's outstanding technology and quality. Equipped with free-step ultimate counterbalance system and variable drag switch system operatable in low-temperature.

RS



Heads & Tripods

450

350

250

Advanced Model for Small Cameras

DUAL HEAD

Dual - head specification available for both 75mm bowl and flat base tripods. Mountable on sliders, skater dollies, and other equipment.



RH25D

Counterbalance range	1.8 to 5kg / 4 to 11lb (C.G.100mm)
Payload	6kg / 13lb
Counterbalance	Continuous Perfect Counterbalance
Drag mode	2STEP
Tilt angle	+90° / -70°
Temperature range	-40°C to +60°C / -40°F to +140°F
Bubble level	Illuminated
Camera plate	Sliding plate
Sliding range	+/-40mm / 1.6"
Head base	75mm ball / Flat base
Plate attachment	1/4" screw with video pin
Spare screw	1/4" and 3/8" screws
Weight	2.5kg / 5.5lb

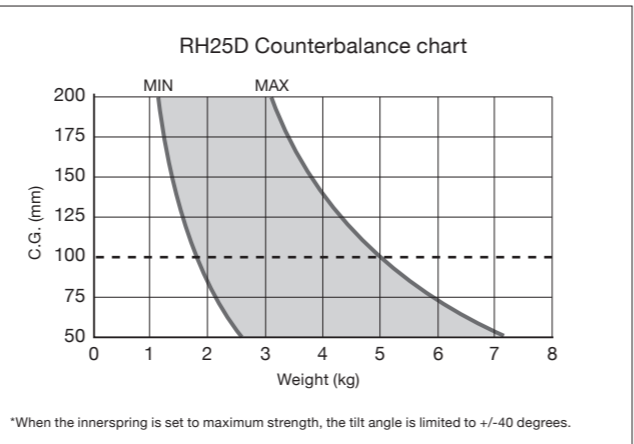

RS-250D

RH25D / RT30B / SP-2B / RC-30
System with floor spreader

Weight	6kg / 13.2lb
Height	55 to 165cm / 21.5 to 65"
Head attachment	75mm bowl
Section	2STAGE



RS-250DM

RH25D / RT30B / BR-2B / FP-2B / RC-30
System with mid-level spreader

Weight	5.7kg / 12.5lb
Height	80 to 164.5cm / 31.5 to 65"
Head attachment	75mm bowl
Section	2STAGE



Recommended Accessories

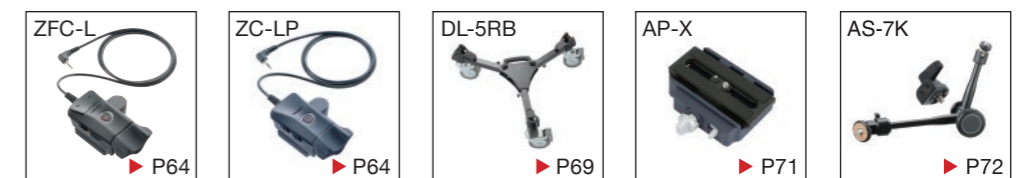

Advanced Model for Large Camcorders

DUAL HEAD

Dual - head specification available for both 75mm bowl and flat base tripods. Mountable on sliders, skater dollies, and other equipment.



RH35D

Counterbalance range	3 to 7.5kg / 6.5 to 16.5lb (C.G.100mm)
Payload	9kg / 20lb
Counterbalance	Continuous Perfect Counterbalance
Drag mode	Free plus 3STEP
Tilt angle	+90° / -70°
Temperature range	-40°C to +60°C / -40°F to +140°F
Bubble level	Illuminated
Camera plate	Sliding plate
Sliding range	+/-40mm / 1.6"
Head base	75mm ball / Flat base
Plate attachment	1/4" screw with video pin
Spare screw	1/4" and 3/8" screws
Weight	2.7kg / 5.9lb

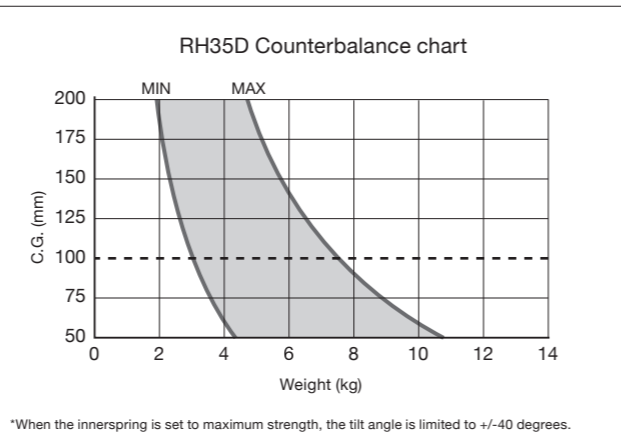

RS-350D

RH35D / RT30B / SP-2B / RC-30
System with floor spreader

Weight	6.2kg / 13.6lb
Height	56 to 166cm / 22 to 65.5"
Head attachment	75mm bowl
Section	2STAGE



RS-350DM

RH35D / RT30B / BR-2B / FP-2B / RC-30
System with mid-level spreader

Weight	6.9kg / 13lb
Height	81 to 165.5cm / 32to 65"
Head attachment	75mm bowl
Section	2STAGE



Recommended Accessories

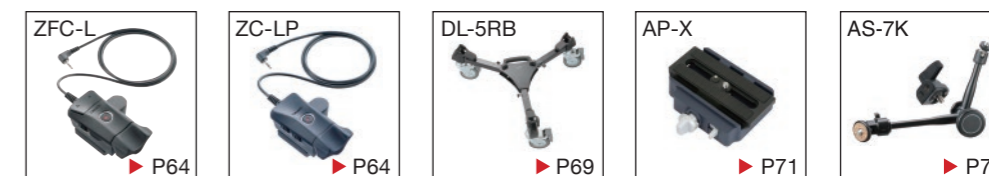

Advanced Model for Large Sensor Cameras and Shoulder Cameras

DUAL HEAD

Dual - head specification available for both 75mm bowl and flat base tripods. Mountable on sliders, skater dollies, and other equipment.



RH45D

Counterbalance range	4.5 to 10.5kg / 10 to 23lb (C.G.100mm)
Payload	12kg / 26.5lb
Counterbalance	Continuous Perfect Counterbalance
Drag mode	Free plus 3STEP
Tilt angle	+90° / -70°
Temperature range	-40°C to +60°C / -40°F to +140°F
Bubble level	Illuminated
Camera plate	Sliding plate
Sliding range	+/-40mm / 1.6"
Head base	75mm ball / Flat base
Plate attachment	1/4" screw with video pin
Spare screw	1/4" and 3/8" screws
Weight	2.7kg / 5.9lb

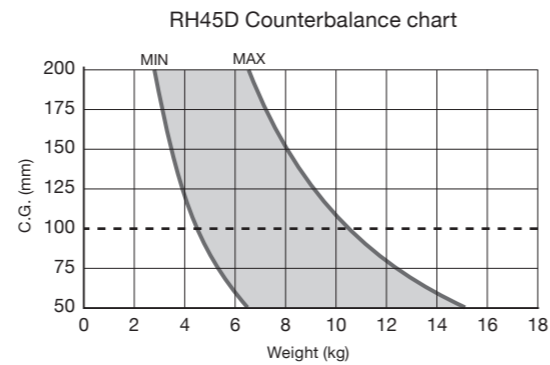

*When the innerspring is set to maximum strength, the tilt angle is limited to +/-40 degrees.

RS-450D

RH45D / RT40RB / SP-2B / RC-50
System with floor spreader

Weight	6.7kg / 14.7lb
Height	63 to 173cm / 25 to 68"
Head attachment	75mm bowl
Section	2STAGE



RS-450DM

RH45D / RT40RB / BR-6B / FP-2B / RC-50
System with mid-level spreader

Weight	6.5kg / 14.3lb
Height	82.5 to 171cm / 32.5 to 67.5"
Head attachment	75mm bowl
Section	2STAGE



Recommended Accessories

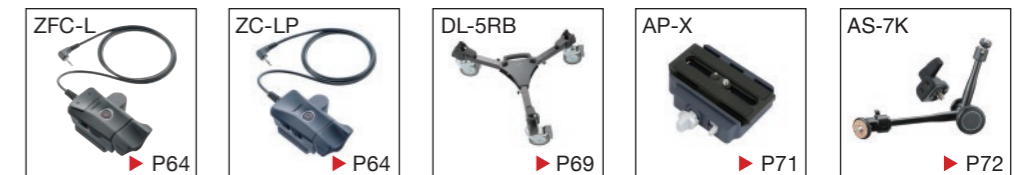

RS PLUS



The perfect controllability captures every single movement. Setup, shooting and transportation. Excellent, user-friendly for all situations. Libec's stylish and highly-developed technology leads to a new tripod range. From the studio to the EFP and OB, RS PLUS series is the perfect tripod system for every broadcast production.

RS + PLUS

750

850

Heads & Tripods

High Performance Model for Shoulder Cameras
Used in Studios, OB, and ENG



SNAP ON/OFF PLATE

The camera plate is attachable and detachable with just one touch, promoting speedy and easy setup.



RHP75

Counterbalance range	5.5 to 14kg / 12 to 31lb (C.G.125mm)
Payload	17kg / 37.5lb
Counterbalance	Continuous Perfect Counterbalance
Drag mode	7STEP
Tilt angle	+90° / -70°
Temperature range	-40°C to +60°C / -40°F to +140°F
Bubble level	Illuminated
Camera plate	Sliding plate
Sliding range	+/-55mm / 2.2"
Head base	100mm ball
Plate attachment	3/8" screw x 2
Spare screw	3/8" screw
Weight	4kg / 8.8lb

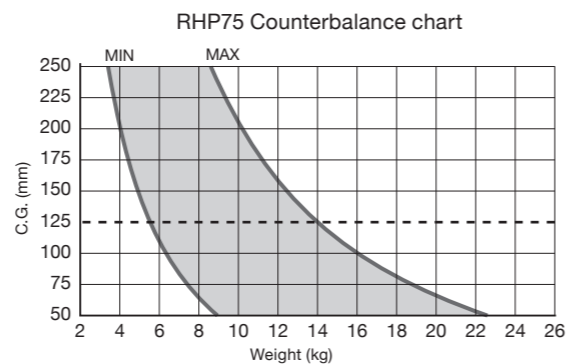

*When the innerspring is set to maximum strength, the tilt angle is limited to +/-40 degrees.



RSP-750

RHP75 / RT50B / SP-2B / RC-70
System with floor spreader

Weight	8kg / 17.6lb
Height	65 to 175.5cm / 25.5 to 69"
Head attachment	100mm bowl
Section	2STAGE



RSP-750C Carbon pipe

RHP75 / RT50C / SP-2B / RC-70
System with floor spreader

Weight	7.7kg / 16.9lb
Height	65 to 175.5cm / 25.5 to 69"
Head attachment	100mm bowl
Section	2STAGE



RSP-750M

RHP75 / RT50B / BR-6B / FP-2B / RC-70
System with mid-level spreader

Weight	7.8kg / 17.2lb
Height	85 to 173.5cm / 33.5 to 68.5"
Head attachment	100mm bowl
Section	2STAGE



RSP-750MC Carbon pipe

RHP75 / RT50C / BR-6B / FP-2B / RC-70
System with mid-level spreader

Weight	7.5kg / 16.5lb
Height	85 to 173.5cm / 33.5 to 68.5"
Head attachment	100mm bowl
Section	2STAGE

Recommended Accessories

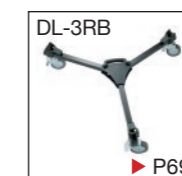

RS PLUS

850

RSP-750PD(B)

RHP75 / P110B / PH-8B(L)

Payload	17kg / 37.5lb
Weight	20.8kg / 45.8lb
Height	101 to 176cm / 40 to 69.5"
Head attachment	100mm bowl
Column	2STAGE



RSP-750PD(S)

RHP75 / P110S / PH-8B(L)

Payload	17kg / 37.5lb
Weight	22.1kg / 48.6lb
Height	99.5 to 174.5cm / 39 to 68.5"
Head attachment	100mm bowl
Column	2STAGE



High Performance Model for Shoulder Cameras
Used in Studios, OB, and ENG



SNAP ON/OFF PLATE

The camera plate is attachable and detachable with just one touch, promoting speedy and easy setup.



Long Plate L

Recommended Accessories

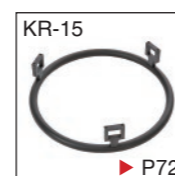

RHP85

Counterbalance range	9 to 20kg / 20 to 44lb (C.G.125mm)
Payload	25kg / 55lb
Counterbalance	Continuous Perfect Counterbalance
Drag mode	7STEP
Tilt angle	+90° / -70°
Temperature range	-40°C to +60°C / -40°F to +140°F
Bubble level	Illuminated
Camera plate	2 Sliding plates (Standard + Long)
Sliding range	+/-55mm / 2.2"(Standard), +/-85mm / 3.3"(Long)
Head base	100mm ball
Plate attachment	3/8" screw x 2
Spare screw	3/8" screw
Weight	4.1kg / 9lb

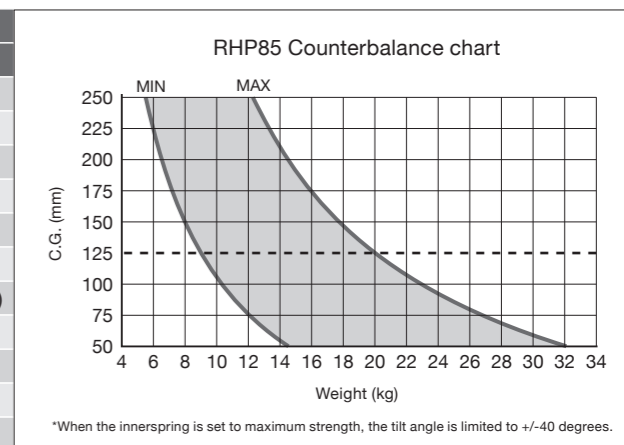

RSP-850

RHP85 / T103B / SP-6B / RC-80
System with floor spreader

Weight	11.8kg / 26lb
Height	79.5 to 191.5cm / 31.5 to 75.5"
Head attachment	100mm bowl
Section	2STAGE

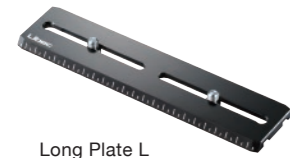

Long Plate L



RSP-850PD(B)

RHP85 / P110B / PH-8B(L)

Payload	25kg / 55lb
Weight	20.9kg / 46lb
Height	101 to 176cm / 40 to 69.5"
Head attachment	100mm bowl
Column	2STAGE



Long Plate L



RSP-850M

RHP85 / T103B / BR-6B / FP-6B / RC-80
System with mid-level spreader

Weight	11.6kg / 25.5lb
Height	95.5 to 189.5cm / 37.5 to 74.5"
Head attachment	100mm bowl
Section	2STAGE



Long Plate L



RSP-850PD(S)

RHP85 / P110S / PH-8B(L)

Payload	25kg / 55lb
Weight	22.2kg / 48.8lb
Height	99.5 to 174.5cm / 39 to 68.5"
Head attachment	100mm bowl
Column	2STAGE



Long Plate L



Recommended Accessories

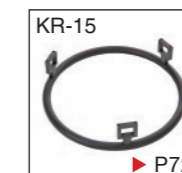

QD



“QD” stands for “Quality Defined”.
 The QD Series redefines the Price Quality
 Relationship in this price range,
 bringing a new balance between price,
 payload, and performance.

QD

Heads & Tripods

30

0

P1000

Flagship Model for Large Prompter Systems and Small Box Lens Systems

SNAP ON OFF PLATE

The camera plate is attachable and detachable with just one touch, promoting speedy and easy setup.



BL-150

QH1/QH1s	QH1	QH1s
Counterbalance range	15 to 35kg / 33 to 77lb (C.G.125mm)	9 to 23kg / 19.8 to 50.7lb (C.G.125mm)
Payload	40kg / 88lb	30kg / 66lb
Counterbalance	Continuous Perfect Counterbalance	
Drag mode	7STEP	
Tilt angle	+90° / -70°	
Temperature range	-20°C to +60°C / -4°F to +140°F	
Bubble level	Illuminated	
Camera plate	Sliding plate	
Sliding range	+/-75mm / 2.9"	
Head base	150mm ball / Flat base with 4 bolts	
Plate attachment	3/8" screw x 2	
Spare screw	3/8" screw x 2	
Weight	12.7kg / 27.9lb	

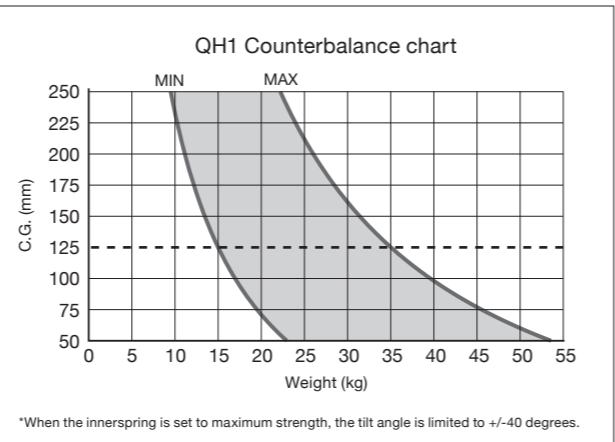

QD-10

QH1 / T150B / SP-15B / BL-150
System with floor spreader

Weight	21.6kg / 47.5lb
Height	82 to 186.5cm / 32.5 to 73.5"
Head attachment	150mm bowl
Section	2STAGE



QD-10M

QH1 / T150B / BR-6B / FP-6B / BL-150
System with mid-level spreader

Weight	21.4kg / 47.1lb
Height	97.5 to 186cm / 38.5 to 73"
Head attachment	150mm bowl
Section	2STAGE



BL-150

QD-10PD

QH1 / P1000 / BL-150

Payload	40kg / 88lb
Weight	39kg / 85.8lb
Height	91.5 to 173cm / 36 to 68"
Head attachment	Flat base with 4 bolts
Column	2STAGE

Recommended Accessories

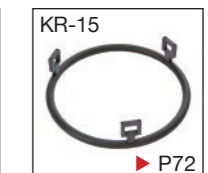
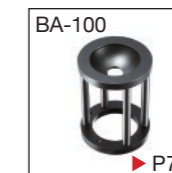
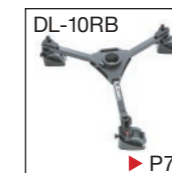
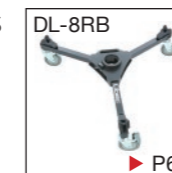

Flagship Model for Mid-size Box Lens Systems

SNAP ON OFF PLATE

The camera plate is attachable and detachable with just one touch, promoting speedy and easy setup.



BL-150

QH3

Counterbalance range	28 to 65kg / 61.6 to 143lb (C.G.125mm)
Payload	69kg / 151.8lb
Counterbalance	Continuous Perfect Counterbalance
Drag mode	7STEP
Tilt angle	+90° / -70°
Temperature range	-20°C to +60°C / -4°F to +140°F
Bubble level	Illuminated
Camera plate	Sliding plate
Sliding range	+/-75mm / 2.9"
Head base	150mm ball / Flat base with 4 bolts
Plate attachment	3/8" screw x 2
Spare screw	3/8" screw x 2
Weight	12.7kg / 27.9lb

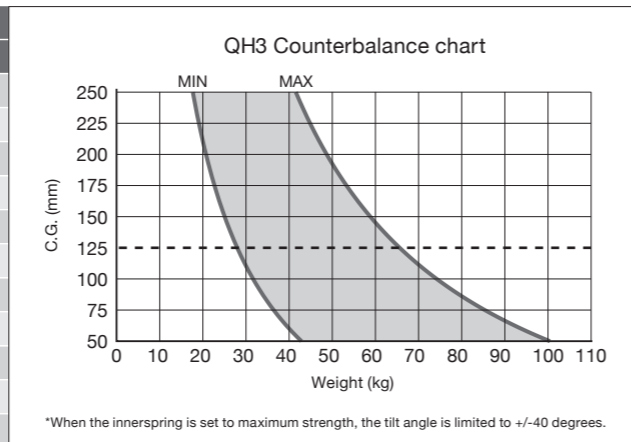

QD-30

QH3 / T150B / SP-15B / BL-150
System with floor spreader

Weight	21.6kg / 47.5lb
Height	82 to 186.5cm / 32.5 to 73.5"
Head attachment	150mm bowl
Section	2STAGE



QD-30M

QH3 / T150B / BR-6B / FP-6B / BL-150
System with mid-level spreader

Weight	21.4kg / 47.1lb
Height	97.5 to 186cm / 38.5 to 73"
Head attachment	150mm bowl
Section	2STAGE



BL-150

QD-30PD

QH3 / P1000 / BL-150

Payload	47kg / 103.4lb
Weight	39kg / 85.8lb
Height	91.5 to 173cm / 36 to 68"
Head attachment	Flat base with 4 bolts
Column	2STAGE

Recommended Accessories

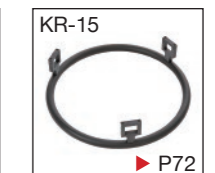
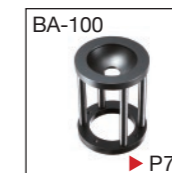
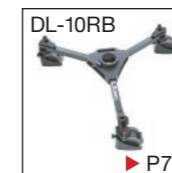
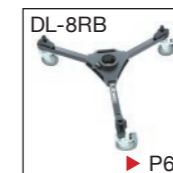

Tripods

150mm
(HEAVY DUTY)



T150B / T150C / T150F **New**

	T150B	T150C	T150F
Pipe material	Aluminum	Carbon	Aluminum
Payload	100kg / 220.5lb	100kg / 220.5lb	100kg / 220.5lb
Weight	6.6kg / 14.5lb *	5.6kg / 12.3lb *	8.1kg / 17.6lb *
Height	58.5 to 163cm 23 to 64" **	58.5 to 163cm 23 to 64" **	58.5 to 163cm 23 to 64" **
Head attachment	150mm bowl	150mm bowl	Flat Base with 4 bolts
Section	2STAGE	2STAGE	2STAGE

Floor spreader
for T150B / T150C / T150F
SP-15B

Weight 1.2kg / 2.6lb



Large rubber feet
for T102B / T103B / T103C / T150B / T150C / T150F
FP-6B

Weight 0.7kg / 1.5lb



100mm
(HEAVY DUTY)



T102B / T103B / T103C **New**

	T102B	T103B	T103C
Pipe material	Aluminum	Aluminum	Carbon
Payload	90kg / 198lb	90kg / 198lb	90kg / 198lb
Weight	5.4kg / 11.9lb *	6.5kg / 14.3lb *	5.4kg / 11.9lb *
Height	69 to 138.5cm 27 to 54.5" **	62 to 174cm 24.5 to 68.5" **	62 to 174cm 24.5 to 68.5" **
Head attachment	100mm bowl	100mm bowl	100mm bowl
Section	1STAGE	2STAGE	2STAGE

Floor spreader
for T102B / T103B / T103C
SP-6B

Weight 1.2kg / 2.6lb



Mid-level spreader
for T102B / T103B / T103C / T150B / T150C / T150F
BR-6B

Weight 0.3kg / 0.7lb



100mm



RT50B / RT50C

Outstanding stability rigidity and weight, with height and portability. Leg joints are equipped with grips for easy transportation.

	RT50B	RT50C
Pipe material	Aluminum	Carbon
Payload	35kg / 77lb	35kg / 77lb
Weight	3.1kg / 6.8lb *	2.8kg / 6.2lb *
Height	47.5 to 157.5cm 18.5 to 62" **	47.5 to 158cm 18.5 to 62" **
Head attachment	100mm bowl	100mm bowl
Section	2STAGE	2STAGE

Floor spreader
for RT40RB / RT50B / RT50C
SP-2B

Weight 0.9kg / 2lb



* The weight excludes spreaders and rubber feet.
** Measured with a floor spreader. The height will differ with a mid-level spreader and rubber feet.
*** Spreaders sold separately.

75mm



RT40RB

Remarkable stability and rigidity with height and portability.

	RT40RB
Pipe material	Aluminum
Payload	35kg / 77lb
Weight	3.1kg / 6.8lb *
Height	47.5 to 157.5cm 18.5 to 62" **
Head attachment	75mm bowl
Section	2STAGE

Mid-level spreader
for RT40RB / RT50B / RT50C
BR-6B

Weight 0.3kg / 0.7lb



Large rubber feet
for RT40RB / RT50B / RT50C
FP-2B

Weight 0.4kg / 0.9lb



* The weight excludes spreaders and rubber feet.
** Measured with a floor spreader. The height will differ with a mid-level spreader and rubber feet.
*** Spreaders sold separately.

Tripods

75mm



75mm



RT30B

Lightweight design, yet ensures high stability and rigidity.

Pipe material	Aluminum
Payload	25kg / 55lb
Weight	2.6kg / 5.7lb *
Height	40.5 to 150.5cm / 16 to 59.5" **
Head attachment	75mm bowl
Section	2STAGE

Floor spreader
for RT30B / RT40RB

SP-2B

Weight 0.9kg / 2lb



Large rubber feet
for RT30B / RT40RB

FP-2B

Weight 0.4kg / 0.9lb



RT20C **New**

Pipe material	Carbon
Payload	25kg / 55lb
Weight	1.6kg / 3.5lb *
Height	37 to 154cm / 14.6 to 60.6" **
Head attachment	75mm bowl
Section	2STAGE

Floor spreader
for RT20C

SP-1B **New**

Weight 0.7kg / 1.5lb



Mid-level spreader
for RT20C / RT30B

BR-2B

Weight 0.2kg / 0.4lb



Large rubber feet
for RT20C

FP-1B **New**

Weight 0.2kg / 0.4lb



* The weight excludes spreaders and rubber feet.

** Measured with a floor spreader. The height will differ with a mid-level spreader and rubber feet.

*** Spreaders sold separately.

Pedestal Systems



Pedestal Systems

P110

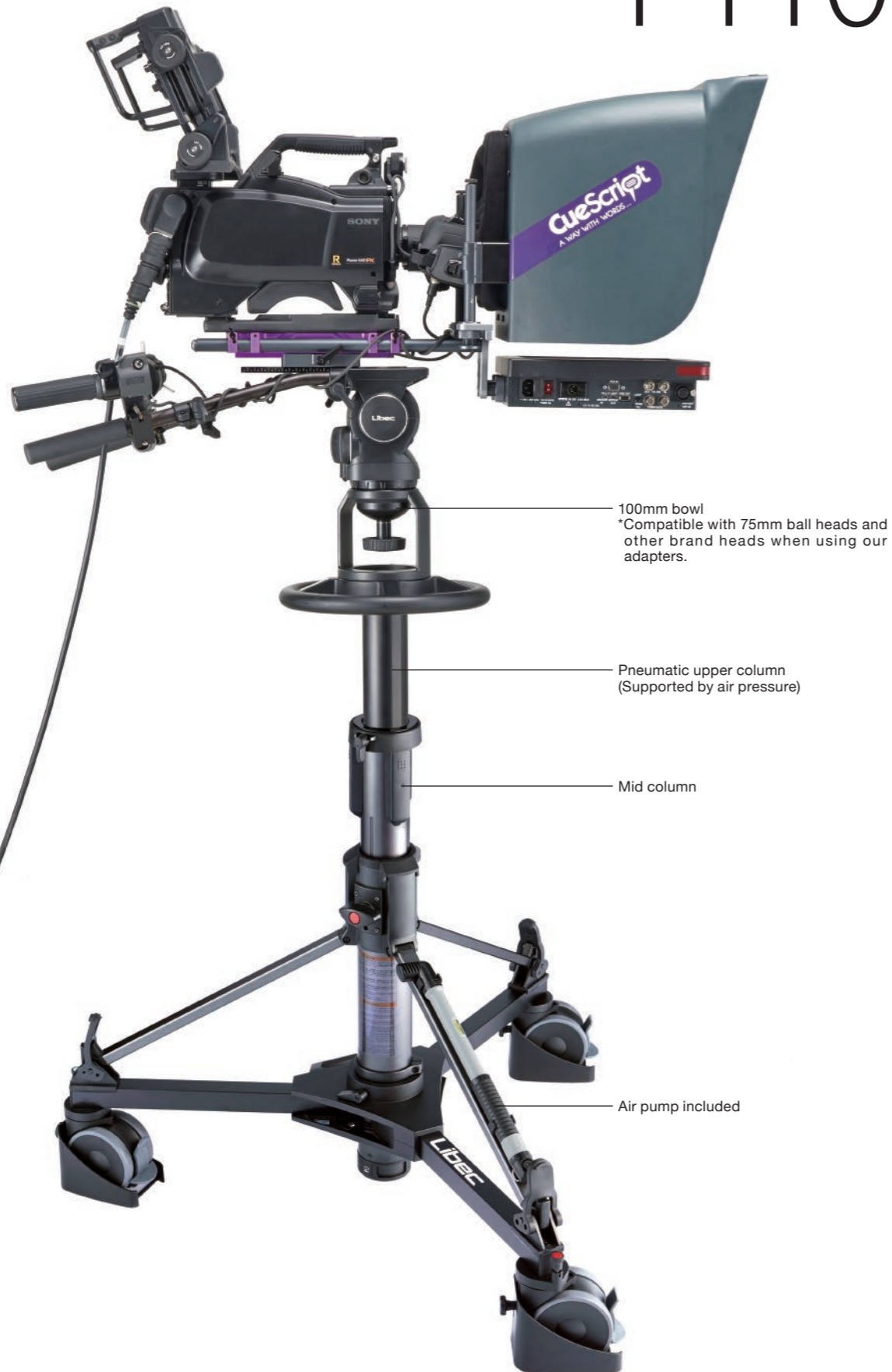

100mm bowl
*Compatible with 75mm ball heads and other brand heads when using our adapters.

Pneumatic upper column
(Supported by air pressure)

Mid column

Air pump included

P110B Outside Broadcast Version

Large sized 125mm/4.9" casters provide quick smooth movement. The double stopper mechanism enables a one-touch locking of the wheel.



Payload	30kg / 66lb
Weight	15.1kg / 33.2lb
Height	82.5 to 157.5cm / 32.5 to 62"
Head attachment	100mm bowl
Column	2STAGE



P110S Studio Version

The P110S is equipped with large high performance 125mm/4.9" casters with removable cable guards. The casters has a track lock mechanism which allows users to set and move the dolly in three different modes: Free Mode, Tracking Mode, and Steer Mode. The caster's locking sound is minimal.

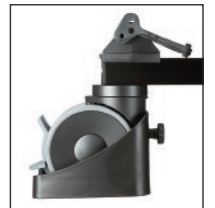

Payload	30kg / 66lb
Weight	18.6kg / 40.9lb
Height	81 to 156cm / 32 to 61.5"
Head attachment	100mm bowl
Column	2STAGE



P110S Compact Compact Studio Version

Payload	30kg / 66lb
Weight	17kg / 37.5lb
Height	81 to 156cm / 32 to 61.5"
Head attachment	100mm bowl
Column	2STAGE



Recommended Accessories

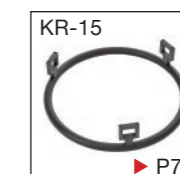

Pedestal Systems

P1000



Flat base with high compatibility

Easy-read air pressure gauge

Detachable steering handle

Upper column with perfect balance feature

Drag knob for upper column

Mid column with gas spring assist

KR-15 (optional)

High performance casters with track lock mechanism

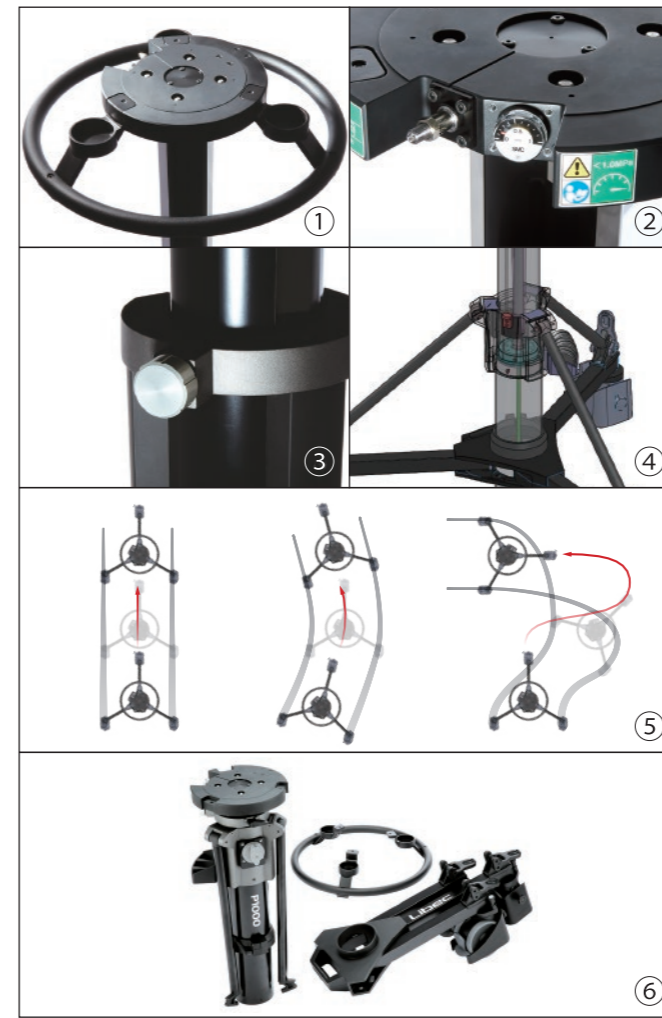

- ① Not only compatible with Libec heads but other brand heads as well. With optional accessories, ball based heads can also be attached on this pedestal.
- ② Air pressure can be easily checked with the air pressure meter.
- ③ Upper column friction can be adjusted to preferred settings with the drag knob.
- ④ The gas spring inside the P1000 pedestal supports the mid column's elevation, allowing safe and easy height adjustments and setups with heavy equipment.
- ⑤ The high performance 125mm large casters are equipped with removable cable guards. The casters has a track lock mechanism which allows users to set and move the dolly in three different modes: Free Mode, Tracking Mode, and Steer Mode. The caster's locking sound is minimal.
- ⑥ The P1000 can be easily disassembled into the P1000 Column, the steering handle, and the dolly. This makes the P1000 easy to transport within studios and outside broadcast sites.



Recommended Accessories



P1000

Payload	60kg / 132lb
Column elevation mechanism	Upper : Perfect balance supported by air pressure Lower : Gas spring assist
Column	2STAGE
Upper stroke	41.5cm / 16.3"
Lower stroke	39.5cm / 15.6"
Stroke range	81cm / 31.9"
Head attachment	Flat base with 4 bolts
Steering handle	Removable steering handle
Pressure adjustment	Air pressure (Standard air pump equipped)
Kick ring	Available (Optional)
Height	68 to 149cm / 26.8 to 58.7"
Weight	26.3kg / 57.9lb



Tracking Rails

Tracking rail kit **TR-320**

1. Dolly carrying case
2. Dolly
3. Rail carrying case
4. Rail (80cm / 31.5" pipe x 8)
5. Rail stopper



Smooth and Versatile

The TR-320 professional track rail includes a set of 80cm/31.5" aluminum pipes to construct 320cm/126" of smooth track rail. The dolly is equipped with high-performance bearings that prevent derailing. The TR-320 offers smooth movements along straight or curved rails. With a smart screw-in design, TR-320 pipes can be easily connected. Optional CR-90 curved rail and the EX-160S straight extension rails are also available, offering more versatile shots in most environments.

Straight extension rail **EX-160S**

Extension length	160cm / 63"
Weight	2.3kg / 5.1lb

VP KIT

Adapter of Vinten tripods for Libec TR-320 Tracking rail kit.



90 degrees curved rail **CR-90**

The CR-90 is a versatile 90° curved extension rail that can be used with the TR-320 to make 45° or 90° curves.



Outer rail radius	168cm / 66"
Weight	3.5kg / 7.7lb

List of Vinten tripods tested with VP KIT

Brands	Head / Tripod Systems	Tripods
Vinten	Vision blue	3819-3
	Vision blue3	V3822-0001
	Vision blue5	3766-3
	Vision 8AS	3821-3
	Vision 10AS	3772-3
	Vision 100	3773-3
		3884-3
		flowtech

SWIFT JIB



JB40



JB40 KIT **New**

Jib arm	JB40
Tripod	T102B
Dolly	DL-8RB

The JB40 KIT comes with carrying cases for each item.



JB40 **New**



1. Padded carrying case
2. Jib arm
3. 75mm adapter
4. Adjusting weight x 1kg / 2.2lb

Payload	①	20kg / 44.0lb (Main arm length : 100cm / 39.5")
	②	30kg / 66.1lb (Main arm length : 63cm / 24.8")
Main arm length		63 to 100cm / 24.8 to 39.5"
Head attachment		100mm / 75mm bowl
Weight		10.3kg / 22.7lb
Head base		100mm bowl

Compact Design

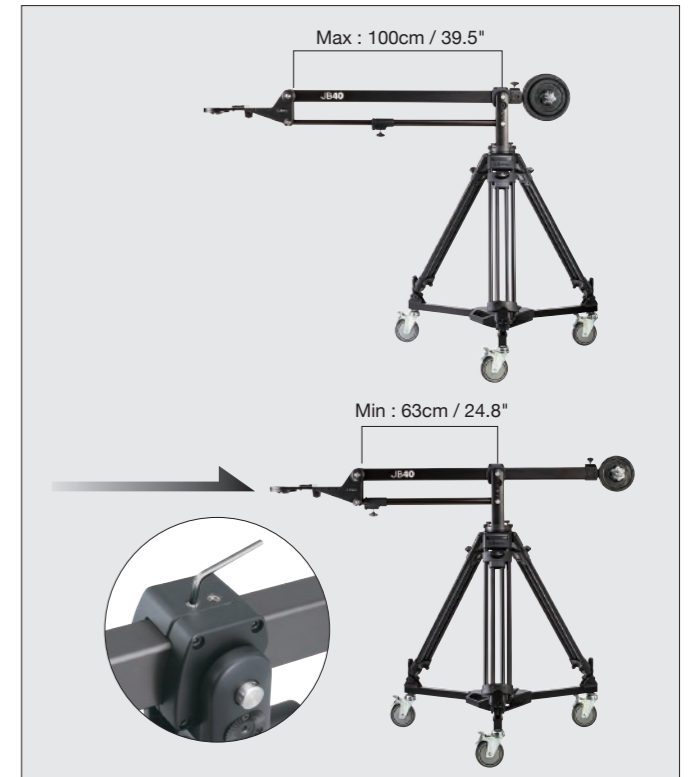

Rigidity

JB40 can support weights up to 20kg and is designed to minimize wobbling or bending of the arm, resulting in smooth and stable camera shots.



High Portability

When folded and stored in its respective included carrying case, the jib arm is only about 120cm in length and easily fits in the trunk of a car. Although the jib arm only weighs 10kg, the case's shoulder strap offers extra support and reduces the burden of transportation.



Redesigned Weight Mounting Method

By changing the weight bar's design from the former JB-30's Screw-in type to a new Plug-in type for the JB40, assembly and break down time is dramatically decreased.

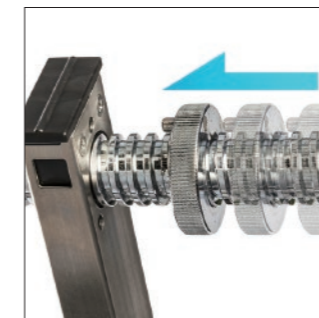

3-Step Easy Setup

Connect the support arms, set the jib on the tripod, and adjust the balance. With only 3 steps, the JB40 is ready for any video production.



SWIFT JIB

Quick, Compact, and Dynamic

The JB50 is designed with a telescopic arm extendable to 90cm/35.5". In addition, the JB50 offers a quick and easy setup, great portability with the supplied carrying cases, and is the ideal solution when shooting film or video with a small crew.

JB50 KIT **New**

Jib arm	JB50
Tripod	T102B
Dolly	DL-8RB

The JB50 KIT comes with carrying cases for each item.



JB50 **New**



1. Padded carrying case
2. Jib arm
3. 75mm adapter
4. Adjusting weight x 1kg / 2.2lb

Payload	①	20kg / 44lb (Main arm length : 100cm / 39.5")
	②	15kg / 33lb (Main arm length : 145cm / 57")
	③	10kg / 22lb (Main arm length : 190cm / 75")
Main arm length	100 to 190cm / 39.5 to 75"	
Weight	16.4kg / 36.1lb	
Head base	100mm bowl	

Telescopic jib



WEIGHT30 KIT

Standard weight kit of 30kg / 66lb:
2 sets of 15kg / 33lb weights
(5kg / 11lb x 2,
2.5kg / 5.5lb x 2)



Clamp handle for JB50 HANDLE50

The HANDLE50 can be clamped on the weight bar of the JB50.



Recommended Accessories



REMOTE HEAD

REMO30

Capture Your Imagination from Start to Finish

The REMO30 is a first-class remote head that exceeds expectations. A unique drive system allows every movement to be traced at the ideal speed. The REMO30 is splash proof, meeting IPX2 standards, and it can endure outdoor shoots under severe climate conditions. In addition, the REMO30 is

an universal remote head that can be used with other equipment such as tripods and jib arms you may already own. You can also enhance your experience with a number of optional products such as Libec remote controls and other accessory supports.

Payload	5kg / 11lb
Weight (Pan and tilt head)	4.5kg / 9.9lb
Weight (Control box)	0.7kg / 1.5lb
360°pan / tilt speed	9sec.
Power supply	AC100-240V DC12V



1. Pan and tilt head
2. Control box
3. Adapter plate
4. AC / DC adapter
5. 5m / 16.5' control cable for head, LANC and monitor
6. 5m / 16.5' HDMI cable
7. 1m / 3.3' LANC cable
8. 1m / 3.3' BNC cable
9. BNC to RCA adapter
10. HDMI to Mini HDMI adapter
11. Carrying case



* LANC is a registered trademark of Sony Corporation.

A Perfect, Bird's-eye View

When mounted upside down, you can achieve a complete bird's-eye shot.



Mounts on 75mm/100mm Jib Arms and Tripods

Available for both 75mm and 100mm bowl equipment.

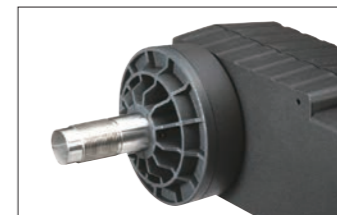

Variable Speed Control



Pan & Tilt Lock System

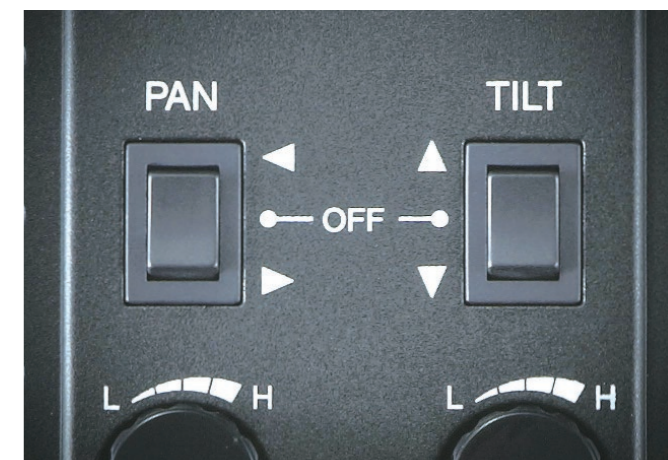

Battery Powered Operations



Control cable for REMO30, LANC* and monitor **CABLE500**

Length 5m / 16.5'



Control cable for REMO30, and LANC* **CABLE5000**

Length 50m / 165'

Video signal cable is not included.



* LANC is a registered trademark of Sony Corporation.

** If the cable length exceeds 30m/99.0", it may cause noticeable noise on the monitor.

Remote Controls

Zoom speed can be adjusted by tilting the Rocker. The Inverted Switch is a new function that changes the zoom direction when the control is attached faced down. The clamp can be attached to round pipes up to 45mm in diameter, wide enough to fit the TH-M Monopod grip.

Zoom & focus control for LANC* video cameras **ZFC-L**

Weight	0.12kg / 0.3lb
Size	80 x 55mm / 3.1 x 2.2"
Cable length	0.7m / 2.3'

	LANC
Zoom	✓
Focus	✓
REC / STOP	✓
Inverted switch	✓



Zoom control for LANC*/Panasonic video cameras **ZC-LP**

Weight	0.12kg / 0.3lb
Size	80 x 55mm / 3.1 x 2.2"
Cable length	0.7m / 2.3'

	LANC	Panasonic
Zoom	✓	✓
Focus		
REC / STOP	✓	✓
Inverted switch	✓	✓



* LANC is a registered trademark of SONY corporation.

Recommended Accessories



Remote Controls

REC Remote Control for Atomos recorders and other LANC* equipment

REC-LA **New**

REC-LA enables remote Rec start/stop for a recorder with a built-in monitor found in Atomos and Blackmagic Design, and LANC*-equipped cameras. The remote control offers wonderful assistance to users holding a gimbal with both hands or shooting with a heavily rigged camera.

Weight	110g / 0.24lb
Cable length	1m / 3.3'



Zoom control for Canon and Fujinon 8 Pin lenses

ZC-9Pro

Weight	0.17kg / 0.37lb
Cable length	0.7m / 2.3'

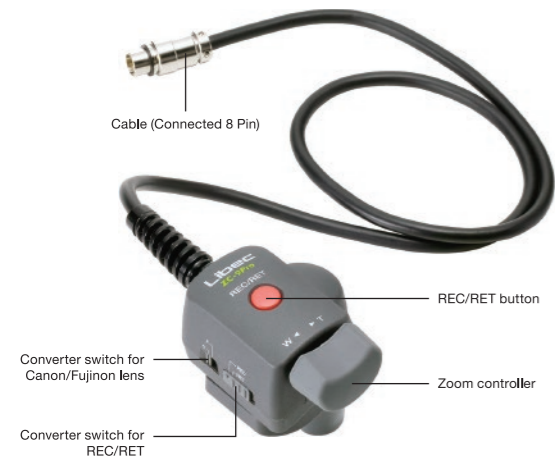

Zoom control for SONY PMW EX cameras

ZC-9EX

Zoom Control for SONY PMW EX cameras. The ZC-9EX can also be used as a ZC-9PRO 8-pin ENG Zoom Control by removing the supplied A-9EX adapter.

Weight	0.2kg / 0.44lb
Cable length	0.7m / 2.3' (main cable) 0.1m / 0.3' (A-9EX)



* LANC is a registered trademark of SONY corporation.
** Not available for XDCAM EX cameras.

Recommended Accessories



Tripod Cases

RC-10

Internal dimension 93cm / 36.5"



RC-20 **New**

Internal dimension 100cm / 39.5"



RC-30

RC-30 is a portable tripod case that enables quick, easy, and smooth storage. Opens wide and flat for use as a floor mat for your equipment at shooting sites.

Internal dimension 85cm / 33.5"



RC-50

RC-50 is a well-designed tripod case for quick and easy storage with high durability and lightweight portability.

Internal dimension 92.5cm / 36.4"



Tripod Cases

The All-round Tripod Case for Easy Transportation

The case is equipped with two wheels and can be pulled along by the side handle grip, which allows easy transportation on foot. Damages are prevented by the soft and hard protectors on all sides of the case which absorb impacts, while the inner strap holds the tripod firmly in place. This all-round tripod case is designed with high rigidity and can be safely transported as a check-in luggage during flights.

List of models storable in the RC-70/RC-80 tripod case

	Model	Transport length	
Vinten	V10AS-AP2F	86.6cm / 34.1"	✓
	V10AS-CP2F	86.6cm / 34.1"	✓
	V100-AP2	85.9cm / 33.8"	✓
	V100-CP2	85.9cm / 33.8"	✓
Sachtler	SYSTEM18 S1 ENG 2	89cm / 35"	✓
	SYSTEM18 S1 ENG 2 CF	89cm / 35"	✓
	SYSTEM20 S1 HD CF	94cm / 37"	✓*
	SYSTEM20 S1 HD MCF	94cm / 37"	✓*
	SYSTEM20 S1 SL HD MCF	94cm / 37"	✓*

* Storable in the RC-70 tripod case, however space may be tight as the tripod system's size is 1cm / 0.4" longer than the internal length of RC-70.

RC-70

Internal dimension	93cm / 36.5"
--------------------	--------------



RC-80

Internal dimension	107cm / 42"
--------------------	-------------



Caster Inner pocket with zipper Handle grip Side handle Inner strap

Camera Bags

Urban CamBag

Transport Your Camera with Style



Urban CamBag 12

Urban CamBag 17

Camera storage dimensions	W265×H170×D135mm / W:10.4"×H:6.7"×D:5.3"	W285×H180×D135mm / W:11.2"×H:7.1"×D:5.3"
Upper storage space dimensions	W265×H210×D115mm / W:10.4"×H:8.3"×D:4.5"	W285×H260×D115mm / W:11.2"×H:10.2"×D:4.5"
Laptop storage dimensions	W265×H345×D20mm / W:10.4"×H:13.6"×D:0.8"	W285×H405×D25mm / W:11.2"×H:15.9"×D:1"
Outer dimensions	W290×H390×D200mm / W:11.4"×H:15.4"×D:7.9"	W300×H450×D200mm / W:11.8"×H:17.7"×D:7.9"
	Without the handles and the shoulder belts	Without the handles and the shoulder belts
Weight	1050g / 2.3lb	1350g / 2.9lb
Material	Nylon	Nylon
Capacity	12 liters	17 liters



Adjustable Partition



Front Pocket



Tripod Holder



Laptop Storage



Carrying Handle Designed for Easy Transportation



Trolley Sleeve



Rain Cover



Sternum and Waist Strap

Broadcast Cambag 30

Camera bag for handheld cameras.

Camera storage dimensions	W480×H260×D180 mm / W:18.9"×H:10.2"×D:7"
Outer dimensions	W520×H290×D340 mm / W:20.5"×H:11.4"×D:13.4"
Weight	1650g / 3.6lb
Material	Nylon
Capacity	30 liters



Accessories

Dolly for 650EX / TH-X / TH-Z DL-2RB

Weight 2.0kg / 4.4lb



Standard dolly for RT20C / RT30B / RT40RB / RT50B / RT50C DL-3RB

Weight 3.9kg / 8.6lb



Carrying handle



Available for Vinten and Sachtler video tripods

Versatile length dolly for RT20C / RT30B / RT40RB / RT50B / RT50C DL-5RB

Weight 4.0kg / 8.8lb

Sliding range 15.5cm / 6.1"



Carrying handle

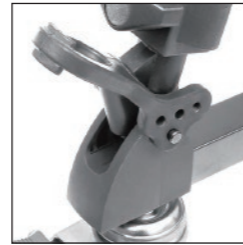

Available for Vinten and Sachtler video tripods

Dolly for T102B / T103B / T103C / T150B / T150C / T150F DL-8RB

Weight 7.3kg / 16.1lb



Carrying handle



Available for Vinten and Sachtler video tripods

Dolly for T102B / T103B / T103C / T150B / T150C / T150F DL-10RB

Weight 8.6kg / 18.9lb



Carrying handle

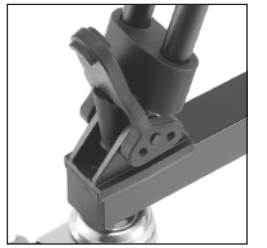

Available for Vinten and Sachtler video tripods

The DL-10RB is equipped with large high performance 125mm/4.9" casters with removable cable guards. The casters has a track lock mechanism which allows users to set and move the dolly in three different modes: Free Mode, Tracking Mode, and Steer Mode. The caster's locking sound is minimal.

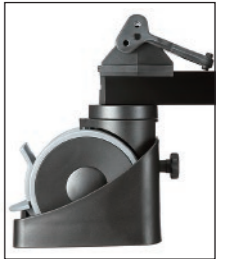

Dolly for RT30B / RT40RB / RT50B / RT50C / T102B / T103B / T103C DL-10RB Compact

Weight 7.8kg / 17.2lb

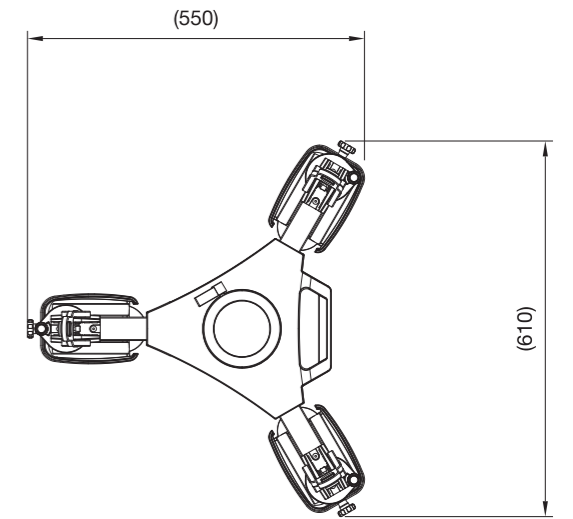

Extendable pan handle for RH25D / RH35D / RH45D PH-6B



Extendable pan handle for RHP75 / RHP85 / LX10 PH-8B / PH-8B(L)



Extendable pan handle for QH1s / QH1 / QH3 PH-15B / PH-15B(L)



Pan handle for LX5 / LX7 PH-5B **New**



AP-X

Weight	0.3kg / 0.7lb
Sliding range	+/-30mm / 1.2"



A-9EX

Conversion zoom cable for 8pin to Sony PMW-EX cameras.



A-3AV

Conversion zoom cable for LANC* to Sony AV remote terminal.



A-12P

Use for 12pin connector.



EX-530DV

Extension zoom cable for LANC* (Sony / Canon) and Panasonic cameras.

Length	5.3m / 17.5'
--------	--------------



EX-530Pro

Extension zoom cable for ENG lenses.

Length	5.3m / 17.5'
--------	--------------



GS-3B **New**

One-Handed Grip for TH-G3.

Weight	330g / 0.73lb
--------	---------------



GD-3B **New**

Two-Handed Grip for TH-G3.

Weight	515g / 1.1lb
--------	--------------



GF-3B **New**

Electric Follow Focus for TH-G3.

Weight	200g / 0.4lb (Motor) 80g / 0.2lb (Controller)
--------	--



GW-600 **New**

Counter weight for TH-G3.

Weight	460g / 1lb
--------	------------



Li-ion battery for TH-G3 **New**



AD-75

Adapter of Libec 75mm heads for 100mm bowl tripods.

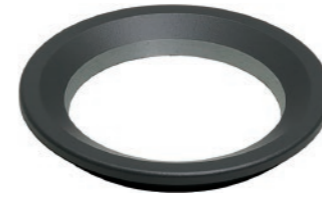

AD-100V

Adapter of Vinten 100mm heads for Libec 100mm bowl tripods.



BL-75R

75mm tripod adapter with bowl clamp.

Weight	0.26kg / 0.6lb
--------	----------------



SS-5 **New**

Monopod set for slider support.



Long Plate S **New**

Long sliding plate for TH-X H / TH-Z H / NH10 / NH30

Weight	0.2kg / 0.4lb
--------	---------------



Long Plate L

Long sliding plate for RHP75 / RHP85 / LX10

Weight	0.2kg / 0.4lb
--------	---------------



AS-7K

Length	261mm / 10.3"
Attachment	1/4" screw
Weight	0.35kg / 0.8lb



BA-100

Adapter of Libec 100mm heads for P1000 pedestal.

Weight	1.1kg / 2.3lb
--------	---------------



BA-150

Adapter of Libec 150mm heads for P1000 pedestal.

Weight	1.8kg / 4lb
--------	-------------



KR-15

Kick Ring for P110 / P1000.



This Kick Ring is a convenient optional accessory for the P1000 / P110B / P110S Pedestal. By pressing on the ring with your foot, the dolly's starting motion is greatly enhanced, resulting in a smoother and easier operability.



* LANC is a registered trademark of SONY corporation.

Specifications

Model	Pedestal	Head	Tripod	Spreader	Case	Dolly	Others	Counterbalance range	Payload	Counterbalance mode	Drag mode	Weight	Height	Ball base	Section
TH-M KIT							—		4kg / 8.8lb	FIX	FIX	2.7kg / 5.9lb	87.5 to 189.5cm / 34.4 to 74.6"	—	2STAGE
650EX	—	—	—	—	RC-10	—	—	—	3kg / 6.5lb	FIX	FIX	3.3kg / 7.3lb	70.5 to 150.5cm / 27.8 to 59.3"	65mm	2STAGE
TH-X	—	TH-X H	—	—	RC-10	—	—	—	4kg / 8.8lb	FIX	FIX	3.1kg / 6.9lb	75.5 ~ 159cm / 29.7 to 62.6"	65mm	2STAGE
TH-Z	—	TH-Z H	TH-Z T	—	RC-10	—	—	—	5kg / 11lb	FIX	FIX	3.5kg / 7.7lb	71.5 to 161.5cm / 28 to 63.5"	75mm	2STAGE
TH-Z S4 KIT	—	TH-Z H	TH-Z T	—	RC-10	—	ALX S4	—	5kg / 11lb	FIX	FIX	4.9kg / 10.8lb	—	75mm	2STAGE
TH-Z S8 KIT	—	TH-Z H	TH-Z T	—	RC-10	—	ALX S8	—	5kg / 11lb	FIX	FIX	5.3kg / 11.7lb	—	75mm	2STAGE
NX-100C	—	NH10	RT20C	SP-1B	RC-20	—	—	0 to 2.5kg / 0 to 5.5lb	4kg / 8.8lb	Free plus 5STEP	Free plus 3STEP	4.1kg / 9lb	53 to 168cm / 20.8 to 66.1"	75mm	2STAGE
NX-100MC	—	NH10	RT20C	BR-2B / FP-1B	RC-20	—	—	0 to 2.5kg / 0 to 5.5lb	4kg / 8.8lb	Free plus 5STEP	Free plus 3STEP	3.8kg / 8.3lb	80 to 167cm / 31.4 to 65.7"	75mm	2STAGE
NX-300C	—	NH30	RT20C	SP-1B	RC-20	—	Long Plate S	0 to 10kg / 0 to 22lb	10kg / 22lb	Free plus 5STEP	Free plus 3STEP	4.1kg / 9lb	53 to 168cm / 20.8 to 66.1"	75mm	2STAGE
NX-300MC	—	NH30	RT20C	BR-2B / FP-1B	RC-20	—	Long Plate S	0 to 10kg / 0 to 22lb	10kg / 22lb	Free plus 5STEP	Free plus 3STEP	3.8kg / 8.3lb	80 to 167cm / 31.4 to 65.7"	75mm	2STAGE
LX5	—	LX5 Head	RT30B	SP-2B	TC-70	—	—	—	5kg / 11lb	FIX	FIX	5.5kg / 12.1lb	56 to 166cm / 22 to 65.5"	75mm	2STAGE
LX5 M	—	LX5 Head	RT30B	BR-2B / FP-2B	TC-70	—	—	—	5kg / 11lb	FIX	FIX	5.2kg / 11.4lb	81 to 165.5cm / 32 to 65"	75mm	2STAGE
LX7	—	LX7 Head	RT30B	SP-2B	TC-70	—	—	—	8kg / 17.5lb	FIX	FIX	5.5kg / 12.1lb	56 to 166cm / 22 to 65.5"	75mm	2STAGE
LX7 M	—	LX7 Head	RT30B	BR-2B / FP-2B	TC-70	—	—	—	8kg / 17.5lb	FIX	FIX	5.2kg / 11.4lb	81 to 165.5cm / 32 to 65"	75mm	2STAGE
LX10	—	LX10 Head	RT50B	SP-2B	RC-50	—	—	—	16kg / 35lb	FIX	2STEP	7.6kg / 16.7lb	63 to 173.5cm / 25 to 68.5"	100mm	2STAGE
LX10 M	—	LX10 Head	RT50B	BR-6B / FP-2B	RC-50	—	—	—	16kg / 35lb	FIX	2STEP	7.4kg / 16.3lb	83 to 171.5cm / 32.5 to 67.5"	100mm	2STAGE
LX10 Studio	—	LX10 Head	RT50B	—	—	DL-3RB	PH-8B(L)	—	16kg / 35lb	FIX	2STEP	10.9kg / 24lb	91.5 to 187cm / 36 to 73.5"	100mm	2STAGE
RS-250D	—	RH25D	RT30B	SP-2B	RC-30	—	—	1.8 to 5kg / 4 to 11lb	6kg / 13lb	Continuous	2STEP	6kg / 13lb	55 to 165cm / 21.5 to 65"	75mm	2STAGE
RS-250DM	—	RH25D	RT30B	BR-2B / FP-2B	RC-30	—	—	1.8 to 5kg / 4 to 11lb	6kg / 13lb	Continuous	2STEP	5.7kg / 12.5lb	80 to 164.5cm / 31.5 to 65"	75mm	2STAGE
RS-350D	—	RH35D	RT30B	SP-2B	RC-30	—	—	3 to 7.5kg / 6.5 to 16.5lb	9kg / 20lb	Continuous	Free plus 3STEP	6.2kg / 13.6lb	56 to 166cm / 22 to 65.5"	75mm	2STAGE
RS-350DM	—	RH35D	RT30B	BR-2B / FP-2B	RC-30	—	—	3 to 7.5kg / 6.5 to 16.5lb	9kg / 20lb	Continuous	Free plus 3STEP	5.9kg / 13lb	81 to 165.5cm / 32 to 65"	75mm	2STAGE
RS-450D	—	RH45D	RT40RB	SP-2B	RC-50	—	—	4.5 to 10.5kg / 10 to 23lb	12kg / 26.5lb	Continuous	Free plus 3STEP	6.7kg / 14.7lb	63 to 173cm / 25 to 68"	75mm	2STAGE
RS-450DM	—	RH45D	RT40RB	BR-6B / FP-2B	RC-50	—	—	4.5 to 10.5kg / 10 to 23lb	12kg / 26.5lb	Continuous	Free plus 3STEP	6.5kg / 14.3lb	82.5 to 171cm / 32.5 to 67.5"	75mm	2STAGE
RSP-750	—	RHP75	RT50B	SP-2B	RC-70	—	—	5.5 to 14kg / 12 to 31lb	17kg / 37.5lb	Continuous	7STEP	8kg / 17.6lb	65 to 175.5cm / 25.5 to 69"	100mm	2STAGE
RSP-750M	—	RHP75	RT50B	BR-6B / FP-2B	RC-70	—	—	5.5 to 14kg / 12 to 31lb	17kg / 37.5lb	Continuous	7STEP	7.8kg / 17.2lb	85 to 173.5cm / 33.5 to 68.5"	100mm	2STAGE
RSP-750C	—	RHP75	RT50C	SP-2B	RC-70	—	—	5.5 to 14kg / 12 to 31lb	17kg / 37.5lb	Continuous	7STEP	7.7kg / 16.9lb	65 to 175.5cm / 25.5 to 69"	100mm	2STAGE
RSP-750MC	—	RHP75	RT50C	BR-6B / FP-2B	RC-70	—	—	5.5 to 14kg / 12 to 31lb	17kg / 37.5lb	Continuous	7STEP	7.5kg / 16.5lb	85 to 173.5cm / 33.5 to 68.5"	100mm	2STAGE
RSP-850	—	RHP85	T103B	SP-6B	RC-80	—	Long Plate L	9 to 20kg / 20 to 44lb	25kg / 55lb	Continuous	7STEP	11.8kg / 26lb	79.5 to 191.5cm / 31.5 to 75.5"	100mm	2STAGE
RSP-850M	—	RHP85	T103B	BR-6B / FP-6B	RC-80	—	Long Plate L	9 to 20kg / 20 to 44lb	25kg / 55lb	Continuous	7STEP	11.6kg / 25.5lb	95.5 to 189.5cm / 37.5 to 74.5"	100mm	2STAGE
QD-10	—	QH1	T150B	SP-15B	—	—	BL-150	15 to 35kg / 33 to 77lb	40kg / 88lb	Continuous	7STEP	21.6kg / 47.5lb	82 to 186.5cm / 32.5 to 73.5"	150mm	2STAGE
QD-10M	—	QH1	T150B	BR-6B / FP-6B	—	—	BL-150	15 to 35kg / 33 to 77lb	40kg / 88lb	Continuous	7STEP	21.4kg / 47.1lb	97.5 to 186cm / 38.5 to 73"	150mm	2STAGE
QD-30	—	QH3	T150B	SP-15B	—	—	BL-150	28 to 65kg / 61.5 to 143lb	69kg / 151.8lb	Continuous	7STEP	21.6kg / 47.5lb	82 to 186.5cm / 32.5 to 73.5"	150mm	2STAGE
QD-30M	—	QH3	T150B	BR-6B / FP-6B	—	—	BL-150	28 to 65kg / 61.5 to 143lb	69kg / 151.8lb	Continuous	7STEP	21.4kg / 47.1lb	97.5 to 186cm / 38.5 to 73"	150mm	2STAGE
RSP-750PD(B)	P110B	RHP75	—	—	—	DL-8RB	PH-8B(L)	5.5 to 14kg / 12 to 31lb	17kg / 37.5lb	Continuous	7STEP	20.8kg / 45.8lb	101 to 176cm / 40 to 69.5"	100mm	2STAGE
RSP-750PD(S)	P110S	RHP75	—	—	—	DL-10RB	PH-8B(L)	5.5 to 14kg / 12 to 31lb	17kg / 37.5lb	Continuous	7STEP	22.1kg / 48.6lb	99.5 to 174.5cm / 39 to 68.5"	100mm	2STAGE
RSP-850PD(B)	P110B	RHP85	—	—	—	DL-8RB	PH-8B(L) / Long Plate L	9 to 20kg / 20 to 44lb	25kg / 55lb	Continuous	7STEP	20.9kg / 46lb	101 to 176cm / 40 to 69.5"	100mm	2STAGE
RSP-850PD(S)	P110S	RHP85	—	—	—	DL-10RB	PH-8B(L) / Long Plate L	9 to 20kg / 20 to 44lb	25kg / 55lb	Continuous	7STEP	22.2kg / 48.8lb	99.5 to 174.5cm / 39 to 68.5"	100mm	2STAGE
QD-10PD	P1000	QH1	—	—	—	DL-15B	BL-150	15 to 35kg / 33 to 77lb	40kg / 88lb	Continuous	7STEP	39kg / 85.8lb	91.5 to 173cm / 36 to 68"	Flat	2STAGE
QD-30PD	P1000	QH3	—	—	—	DL-15B	BL-150	28 to 65kg / 61.5 to 143lb	47kg / 103.4lb	Continuous	7STEP	39kg / 85.8lb	91.5 to 173cm / 36 to 68"	Flat	2STAGE